

All Prater Air Classifiers separate particles based on the opposing principles of centrifugal force and aerodynamic drag force. As product enters the primary air inlet, individual particles are subjected to aerodynamic drag forces by the conveying air. This drag force varies with the size and density of the individual particles.

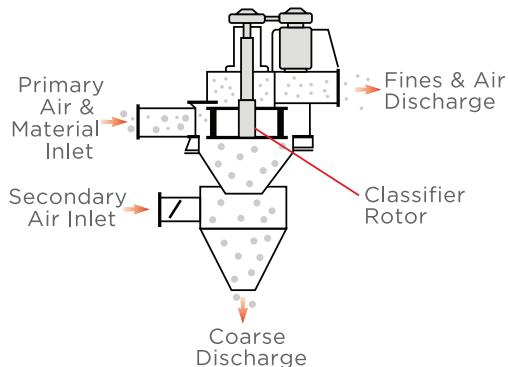

As particles spiral toward the classifier rotor, one of two things occur: 1) drag force exceeds the centrifugal force exerted by the rotor and particles pass through the machine as fines; or 2) centrifugal force overcomes the drag force, causing particles to accelerate away from the rotor, where a cyclonic chamber collects the coarse particles and discharges them. Cut-point is determined when the forces are equal, in which case particles have a 50/50 chance of passing as fines. Cut-point is variable and can be controlled by adjusting the rotor speed.

A secondary air inlet introduces a controllable amount of air that moves upward into the classification zone, increasing the residence time of agglomerated particles. This air helps to increase efficiency for smaller cut-points.

## FEATURES

- Control of mean particle size within 0.5 micron
- Precise on-stream control of cut point through variation of rotor speed
- Excellent sharpness of cut
- Operates under suction promoting a dust-free environment

## MINI-SPLIT

- Operating range of 1 to 75 microns
- Feed rate for 1 to 75 kilograms/hour
- Narrow size distributions
- Stainless steel contact parts

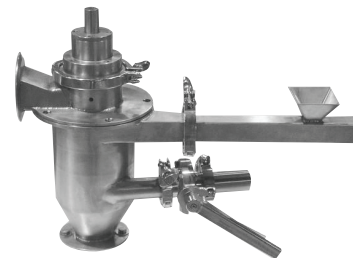

The Mini-Split Classifier was developed specifically for research, “semi-tech” and small-scale production applications. Its low operating noise makes it a preferable option for smaller working spaces and its compact size allows for portability.

With interchangeable components, the Mini-Split can be converted into an opposed jet fluid energy micronizing system, complete with integral classifier, for the size reduction of a wide range of materials.

The Mini-Split’s capacities are adjustable to suit individual customer requirements and can be easily incorporated with a feeder, classifier and/or product collection system.

## MAC

- Operating range of three to 150 microns
- Reduced power consumption due to low system resistance
- Capacities from a few kilograms/hour to many tons/hour
- Mild steel or stainless steel
- Available in seven sizes

MAC forced vortex units process dry materials to exceptional fineness and uniformity over a wide range of feed variations, either in closed-circuit with a conventional milling system, or as independent "stand alone" systems incorporating feeder, fan and product collection equipment.

Such superior performance is due, in part, to a design that ensures that feed material entering the classifying vortex is unimpeded by re-circulating coarse fractions.

The MAC can easily be installed in existing air systems with minimal modification. Available options include ceramic rotors, abrasion-resistant steel and rubber, polyurethane or ceramic lining.

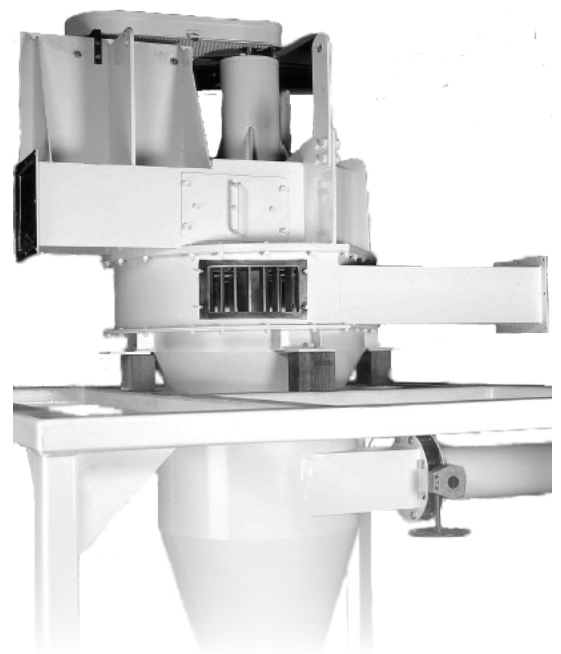

**PRATER**<sup>®</sup>  
AIRLOCKS • MILLS • SEPARATORS

2 Sammons Court, Bolingbrook, IL 60440  
800.323.5735 • [praterindustries.com](http://praterindustries.com)